

Applications: rigid thermoplastic materials.

Assembly: by pressure.

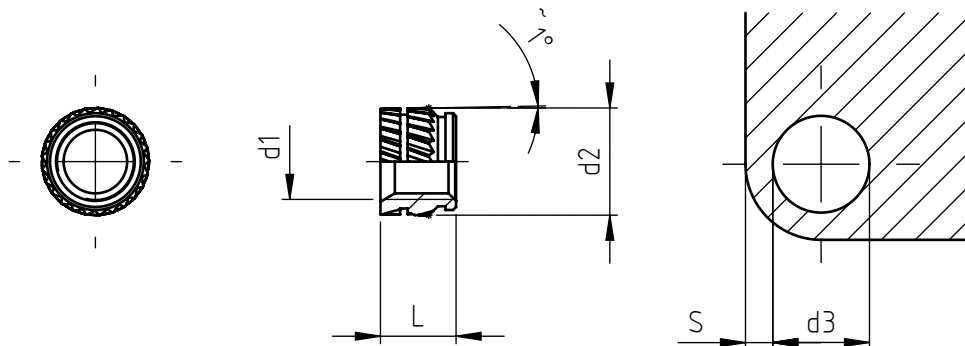

codice	metric thread	external diameter	total length	hole diameter	minimum wall thickness
	d1	d2	L	d3	S
851 0030.80	M 3	4,6	3,0	4,0	2,3
851 0040.80	M 4	6,3	4,0	5,6	2,5
851 0050.80	M 5	7,1	5,0	6,4	2,7
851 0060.80	M 6	8,7	6,0	8,0	3,0

Non binding dimensions, expressed in mm.

For a correct usage of the product it is advisable to carry out some preliminary assembling tests to determine the correct hole diameter.

Standard       On demand

Material: brass  
 Finishing: natural  
 Tolerances: ISO 2768 - m  
 Threading: ISO 6 H

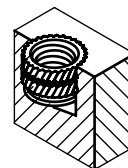

chemical-concepts.com  
**800.220.1966**  
 410 Pike Road • Huntingdon Valley, PA 19006